

DIN 376 HSS-E OX R43,5 

- UK** Special tap for through holes for hard - to - machine materials, e.g. stainless steels.
- D** Spezieller Gewindebohrer für Durchgangsgewinde in schwer zerspanbaren Werkstoffen wie z. B. rostfreien Stählen.
- F** Taraud spécial pour taraudage de matériaux durs comme per ex. acier inoxydable.

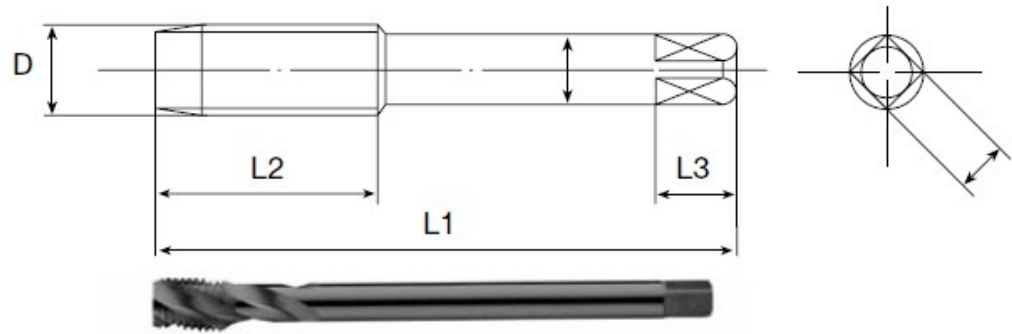

unit: mm

D	P	L1	L2	d h9	L3	a h12	N	stock, ab Lager, stock			
								Tol.6H	Price, Preis, Prix €	Tol.6G	Price, Preis, Prix €
M 6	1.00	80	10	4.5	6	3.4	3	○	13,88 14,90		— —
M 8	1.25	90	12	6.0	8	4.9	3	○	18,67 21,43		— 22,96
M 10	1.50	100	15	7.0	8	5.5	3	○	26,02		27,55
M 12	1.75	110	17	9.0	10	7.0	3	○	31,63 47,45	○	33,16 —
M 14	2.00	110	20	11.0	12	9.0	3	○	53,06 68,37 85,20	○	— — —

Packing unit: 10 pcs,
Verpackungseinheit: 10 Stück,
Unité d'emballage: 10 pcs

N: Number of flutes Zähnezahl Nombre de dents
P: Pitch Steigung Pas