

# Campagnolo and Fulcrum Ultra Torque bearing removal and installation set

1626/2



## Profiles



[./\(eng/support/warranty\).](#)

## Product features

- Designed and built to install and remove the pressed bearing used on Campagnolo® and Fulcrum® Ultra-Torque cranks.
- The bearing puller's forged arms and tapered edges securely pinch under the bearing while the heavy-duty plunger system "pulls" the bearing.

## How to use the tool:

- The installation tool precisely fits both the crank spindle and the press fit bearing to ensure proper installation. Just tap the bearing into place using the tool and a hammer.

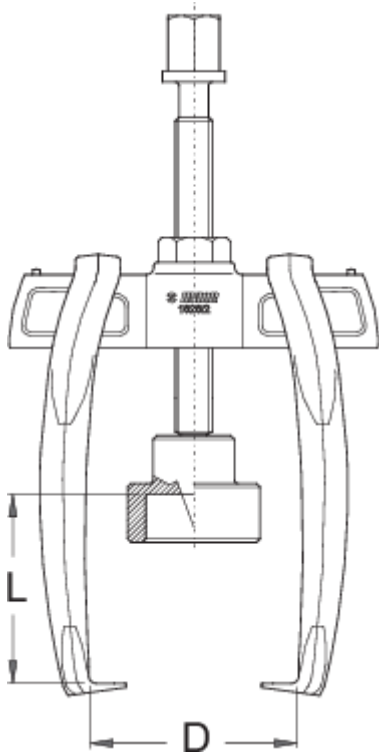

Barcode	L↑	D↓	D↑	Icon
---------	----	----	----	------

621661	75	40	75	464
--------	----	----	----	-----

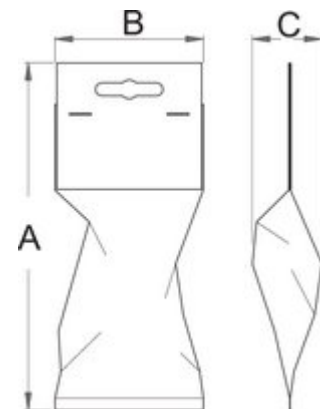

### Retail packaging

Barcode	MA	MB	MC	Icon
---------	----	----	----	------

621661	250	150	34	500
--------	-----	-----	----	-----

### Transport packaging

Barcode	Icon	TA	TB	TC	Icon
---------	------	----	----	----	------

621661	1				
--------	---	--	--	--	--

# Spare parts



Spindle for 1626/2



Tool body 1626/2